

# CHINABASE Precision joints

with quick locking

## Type GR and HR/Protection muffs

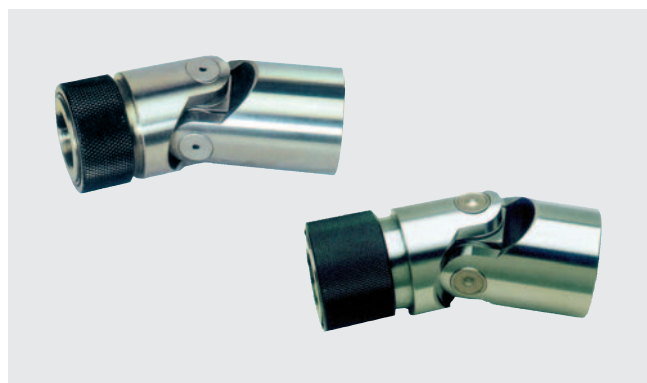

- Precision single joint with quick locking (separable)
- Type GR with plain bearing  $n_{max.} = 1000 \text{ min}^{-1}$
- Type HR with needle bearing  $n_{max.} = 4000 \text{ min}^{-1}$
- Maximum articulation angle  $45^\circ$
- Quick locking ( $d_2$ ) only available with H7 bore and keyway to DIN 6885 sheet 1 - JS9 or hexagon bore

**NEW** ● Sizes 05, 2 and 4 are new in our programme!

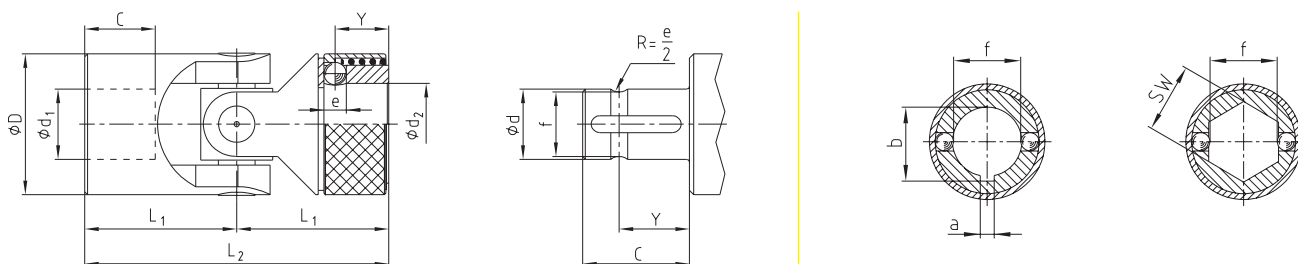

Type GR with plain bearing  $n_{max} 1000 \text{ min}^{-1}$

Type HR with needle bearing  $n_{max} 4000 \text{ min}^{-1}$

Size		$d_1, d_2$ [H7]	D	$L_2$	$L_1$	C	Y	e	f	a [JS9]	b	SW [H8]
GR	HR											
02 GR	-	8	16	52	26	14	9,5	3,5	7,0	2	9,0	8
03 GR	03 HR	10	22	62	31	17	11,5	4,0	8,7	3	11,0	10
04 GR	04 HR	12	25	74	37	21	13,5	4,0	11,0	4	13,3	12
05 GR	05 HR	14	25	74	37	21	13,5	4,0	13,0	5	15,3	14
1 GR	1 HR	16	32	86	43	24	14,0	6,35	14,8	5	17,3	16
2 GR	2 HR	18	36	96	48	28	19,0	8,0	16,0	6	19,8	18
3 GR	3 HR	20	42	108	54	31	19,0	8,0	18,0	6	22,3	20
4 GR	4 HR	22	45	120	60	34	20,5	10,0	20,0	6	24,8	22
5 GR	5 HR	25	50	132	66	38	20,5	10,0	23,0	8	28,3	25
6 GR	6 HR	30	58	166	83	49	25,0	10,0	28,0	8	33,3	30

### Protection muffs for joints type G; H; GA; HA; X

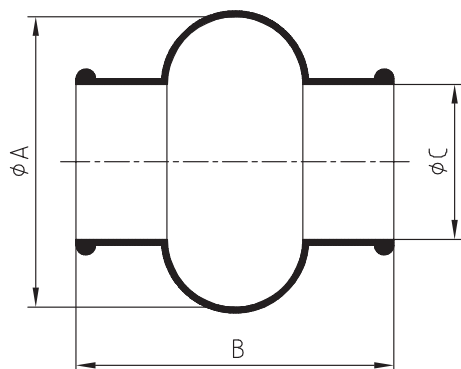

Size	Joints	A	B	C
M 01	01 G, 01 X	28	34	15
M 02	02 G, 02 X	32	40	16,5
M 03	03 G, 03 H, 03 GA, 03 HA, 03 X	40	45	20,5
M 04	04 G, 04 H, 04 GA, 04 HA, 04 X	48	50	24,5
M 05	05 G, 05 H, 05 GA, 05 HA	52	56	27,5
M 1	1 G, 1 H, 1 GA, 1 HA, 1 X	56	65	30,5
M 2	2 G, 2 H, 2 GA, 2 HA	66	72	35,5
M 3	3 G, 3 H, 3 GA, 3 HA, 3 X	75	82	40,0
M 4	4 G, 4 H, 4 GA, 4 HA	84	95	45,0
M 5	5 G, 5 H, 5 GA, 5 HA, 5 X	92	108	50,0
M 6	6 G, 6 G1, 6 H, 6 H1, 6 GA, 6 HA, 6 X	100	122	56,0

Order form:

03 HR	$d_1 = \emptyset 10$	$d_2 = \emptyset 10$ keyway DIN
Size/type of joint	Finish bore (H7)	Finish bore (H7) keyway to DIN 6885 sheet 1 (JS9) – only available with keyway or as hexagon bore –